

RANGER™ POOL LIFT

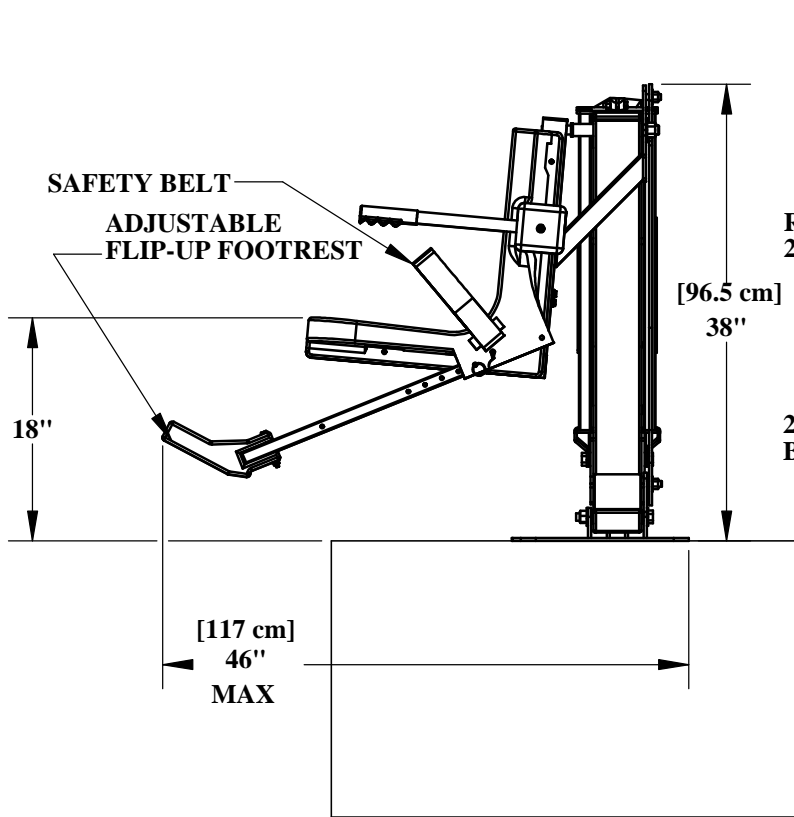

SIDE VIEW

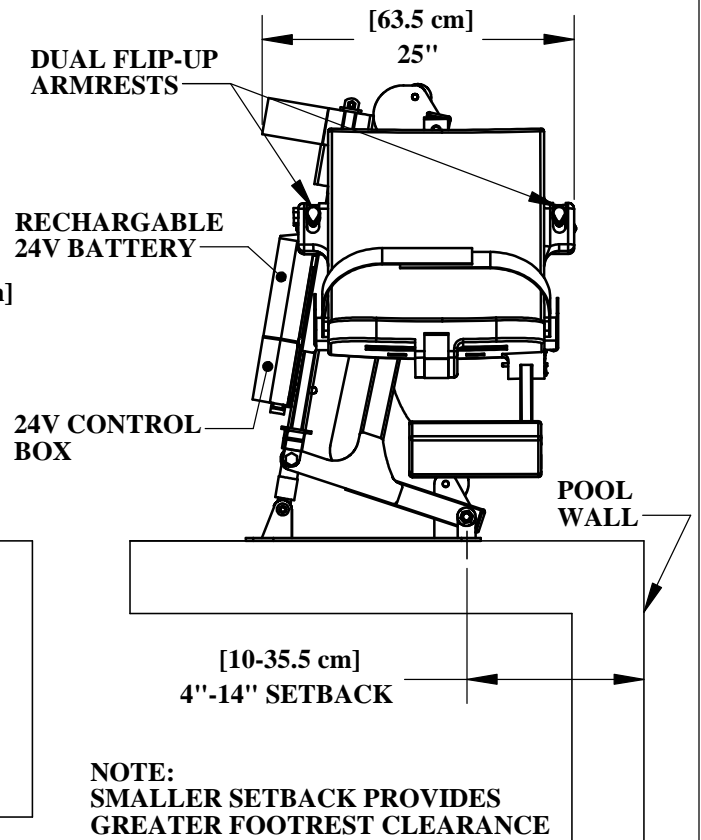

FRONT VIEW

SPECIFICATIONS

THE AQUA CREEK RANGER POOL LIFT SHALL BE A 24V LINEAR ACTUATED, SELF OPERABLE, IN-GROUND POOL OR SPA LIFT. THE LIFT SHALL NOT INTRUDE INTO THE POOL OR SPA UNLESS IN USE. THE LIFT SHALL BE OF STAINLESS STEEL CONSTRUCTION AND DESIGNED TO LIFT 300 LBS [136 kgs]. AN 18" [45.7 cm] WIDE SEAT SHALL BE CAPABLE OF BEING SET BACK 16" [405 mm] FROM CENTERLINE OF SEAT TO POOL EDGE. A 24 VOLT WATERPROOF CONTROLLER SHALL BE USABLE BY THE OPERATOR OR AN ATTENDANT. A CONTROL BOX, BATTERY CHARGER AND ONE REMOVABLE 24V RECHARGABLE BATTERY SHALL COME STANDARD. THE LIFT SHALL INCLUDE A SEATBELT. THE LIFT SHALL CARRY A TWO (2) YEAR WARRANTY ON ALL STRUCTURAL COMPONENTS.

- BASE PLATE: 1/4" STAINLESS STEEL TYPE 304
- MAIN HOUSING: 2" x 4" x .120" STAINLESS STEEL TUBE TYPE 304
- CHAIR AND FOOTREST: UV STABILIZED POLYETHEYLENE (LLDPE)
- ACTUATOR: 24" STROKE LINAK LA34 LINEAR ACTUATOR
- OPTIONAL WHEEL KIT: MOLDED POLYOLEFIN
- FINISH: UV RESISTANT EPOXY POWDER COATING

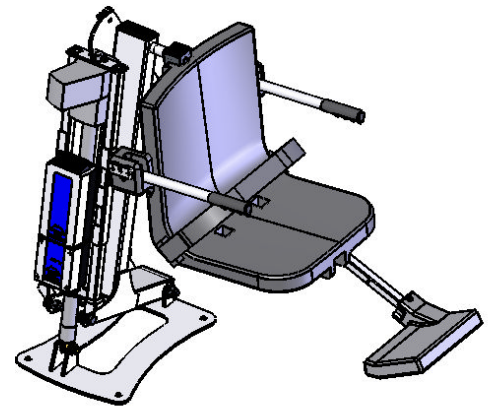

9889 GARRYMORE LANE
 MISSOULA, MT 59808
 (406) 549-0769
 FAX (406) 549-2602

NOTE:
 *SPECIFICATIONS ARE SUBJECT TO CHANGE WITHOUT NOTICE
 *ALL DIMENSIONS ARE IN INCHES

PRODUCT:	F-411RPL	
DWG #:	F-411RPL-1	
SCALE:	1:18	DATE: 11/15/10
DRAWN BY:	DS	REVISION: B

RANGER™ POOL LIFT

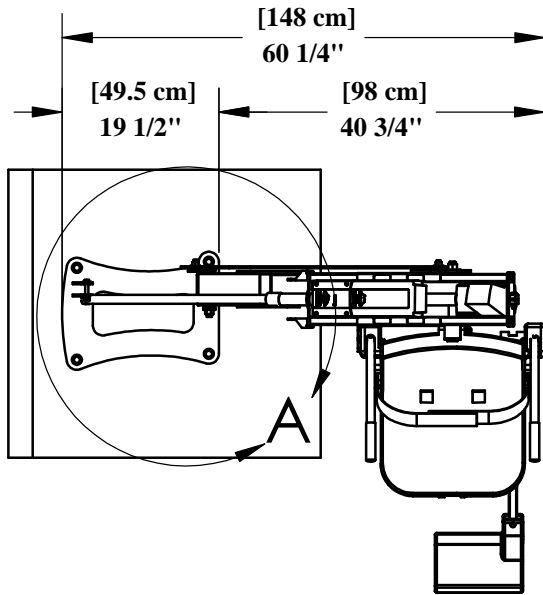

TOP VIEW

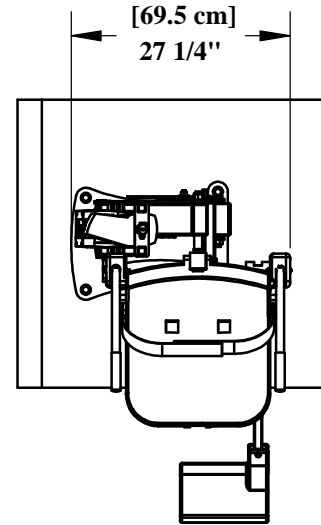

LIFT SHOWN IN FULLY RAISED POSITION

TOP VIEW

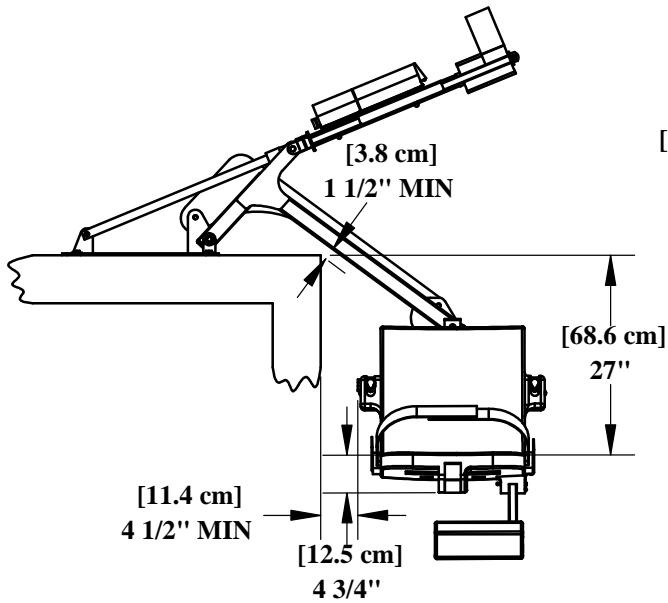

LIFT SHOWN IN FULLY LOWERED POSITION

FRONT VIEW

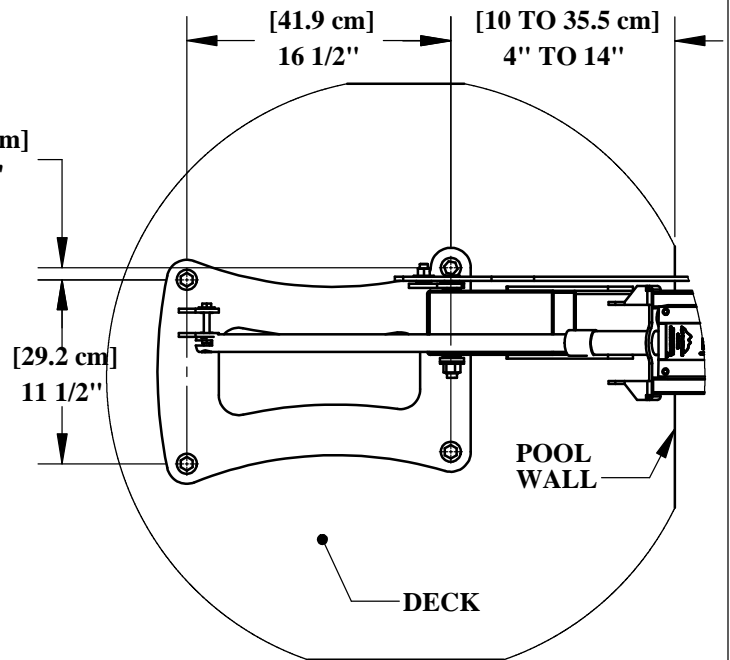

**DETAIL A
SCALE 1 : 12**

ANCHOR BOLT PATTERN



9889 GARRYMORE LANE
MISSOULA, MT 59808
(406) 549-0769
FAX (406) 549-2602

NOTE:
*SPECIFICATIONS ARE SUBJECT TO CHANGE WITHOUT NOTICE
*ALL DIMENSIONS ARE IN INCHES

PRODUCT:	F-411RPL	
DWG #:	F-411RPL-2	
SCALE:	1:24	DATE: 11/15/10
DRAWN BY:	DS	REVISION: B